

CHEMICAL PROCESSING

LEADERSHIP | EXPERTISE | INNOVATION

**IMPROVE
YOUR REFINERY**

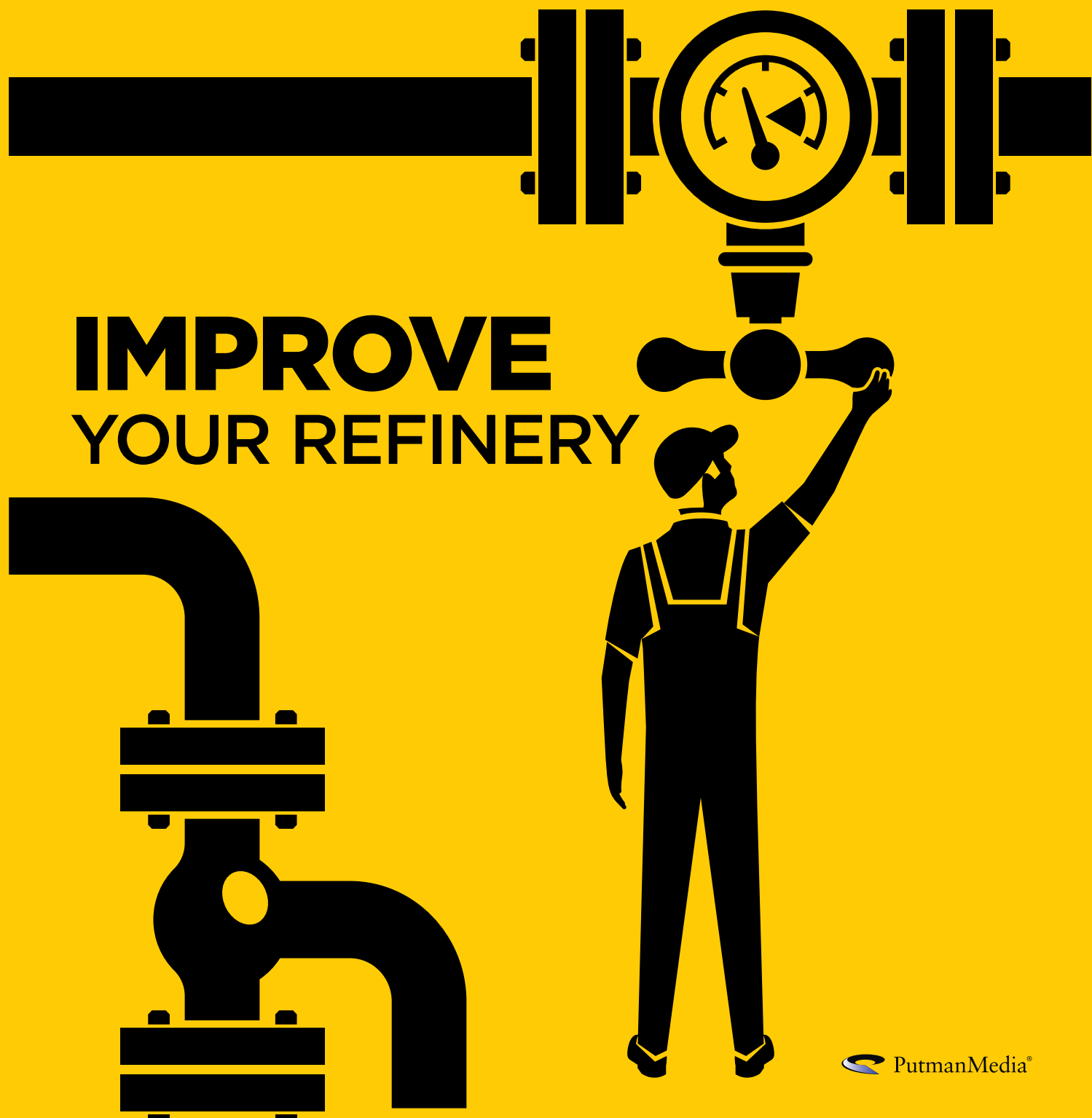

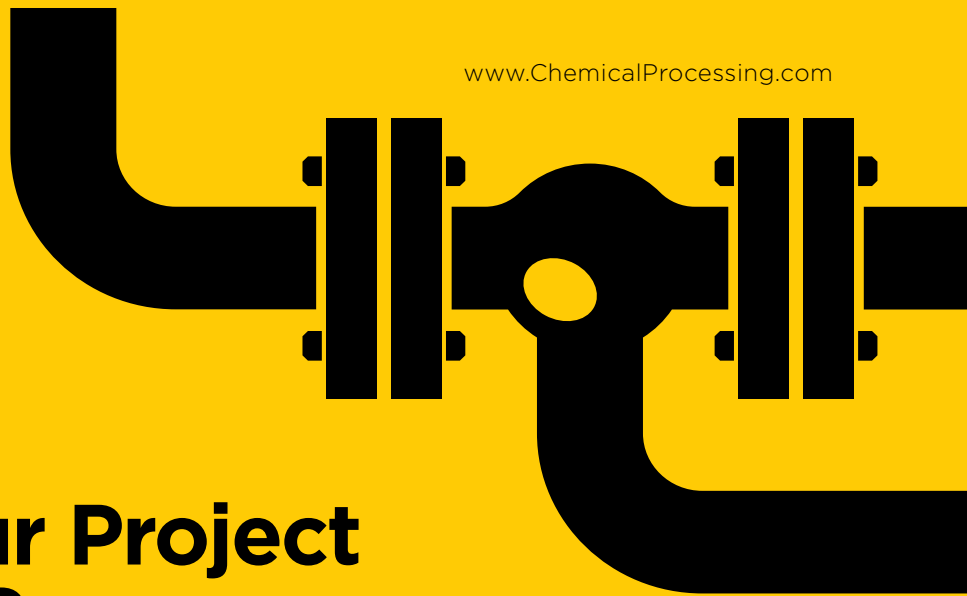

TABLE OF CONTENTS

Tailor Your Project Delivery Process _____	5
Treating every project the same can lead to excessive deliverables or missed steps	
Successfully Sample Sticky Hydrocarbons _____	13
Proper technology and design techniques ensure safe, reliable sampling of viscous and hot process streams	
Mitigate Explosions with Oxygen Measurement _____	19
Select the right oxygen analyzer for your process control requirements	
Successfully Select an Industrial Fan _____	29
Gathering site and fan history is crucial when choosing the right unit for the application	
Additional Resources _____	34

AD INDEX

Baker Hughes • www.panametrix.com _____	4
Magnetrol • steamgen.magnetrol.com _____	2
Pick Heaters, Inc • www.pickheaters.com _____	12
SOR, Inc. • www.sorinc.com _____	28
The New York Blower Company • www.nyb.com _____	18



Tailor Your Project Delivery Process

Treating every project the same can lead to excessive deliverables or missed steps

By Ivan Crespo, Pathfinder, LLC

The project portfolios of many operating companies are shifting from major capital projects to more-modest in-plant ones. This requires an adaptable/scalable project delivery process (PDP) that supports the execution of these projects. Certain aspects of the process apply to all projects, while others only relate to major or more-complex ones. These project-specific planning and execution activities frequently are misunderstood and inappropriately applied — causing excessive project deliverables for some projects but missed steps for others. This inconsistent application of project delivery activities lowers the value generated from the capital employed.

The change in capital project portfolios varies from industry to industry. The

reshaping happening in the chemical and refining sectors reflects uncertainties about future oil prices, the potential impact of shale oil as well as technological advances and environmental demands that aim to replace or reduce the consumption of fossil fuels.

The 2014–2015 drop in oil prices by itself significantly reduced the revenue stream of all oil producers, big and small. This resulted in deferral or redimensioning of large projects; many have been split into smaller projects.

This is not a small change. It requires an important alteration in the approach and resources needed for developing the redimensioned or redefined projects now in the portfolios. The number of projects

probably has changed but, more importantly, many (if not most) of those projects now are smaller.

KEY DIFFERENCES IN PROJECTS

Large and small projects need different tracks for approval, follow-up and execution. While large projects involve a significant number of complex deliverables, small ones typically require a more simplified approach. Consider a very simple analogy — digging holes. If our task (project) was to dig large holes, then probably we'd need an excavator, bulldozer or backhoe. However, if the task has been rethought and now asks for much smaller holes, maybe we only require a simple shovel. This makes a major difference in how things should be done. Instead of contracting for a large piece of equipment and a specialized operator, now we only need someone with a hand tool. The equipment, the “operator” and the skills aren't the same. Failing to recognize this fundamental

differentiator will significantly impact the efficiency, quality, cost and schedule in executing the project. By definition, a bulldozer can't dig small holes and, in turn, you wouldn't use a shovel to dig an enormous one.

In this analogy, the difference is very easy to identify and visualize. However, in a real project, the difference sometimes isn't as apparent because size isn't the only relevant parameter to consider. You may need to review and analyze factors such as technology, strategic importance, complexity, etc., when characterizing a project and defining the right track in the PDP for its successful development/execution.

Regarding the approval and follow-up, the projects of utmost strategic significance, high cost and complexity require the involvement of corporate levels of the organization. This is natural considering the level of resources that such projects

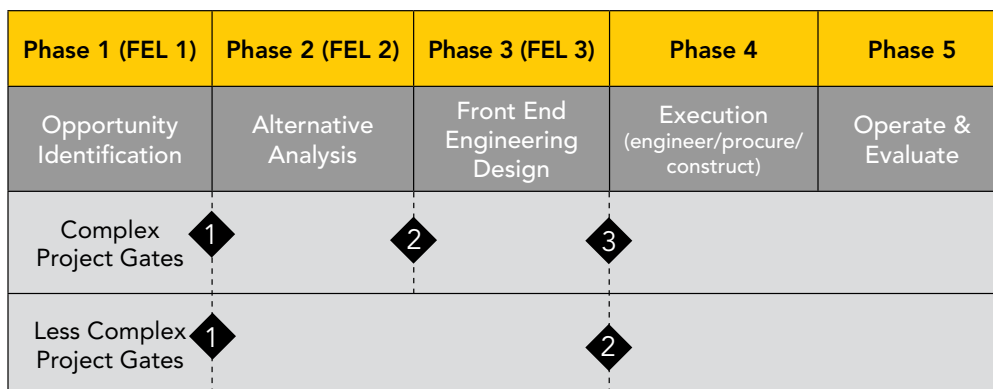

THE PROJECT DELIVERY PROCESS

Figure 1. A small project should involve fewer phase gates.

demand. On the other hand, engineering, maintenance or operational groups generally directly decide about the planning and execution of small capital projects in a process facility, such installing metering systems, new pumps, storage tanks, pipeline loops/bypass, replacing a vessel or revamping or updating utilities. So, as Figure 1 shows, a smaller project doesn't require a phase gate at every stage of front-end loading (FEL).

Think about a large upstream project such as an offshore platform involving a jacket, drilling, topsides, tie-back operations, extensive use of supply vessels, transport and heavy lifting of equipment or whole units and facilities. An operation of this magnitude demands careful planning, design, coordination and integration of thousands of components, many of them fabricated and transported from different parts of the worlds. The specifications, drawings, procedures, etc., to completely define each component and the procedures for assembling, commissioning, starting up and testing such facilities are extraordinary. Each deliverable should be carefully developed at a very high level of detail following protocols (project assurance) that repeatedly, and in a timely manner, check the planning, quality of the design, constructability and integration of the facility. Such protocols include conducting independent reviews, readiness assessments, benchmarking, safety reviews, integrity

reviews, as well as extensive use and application of value improving practices (VIPs), just to name a few. If the components can't be integrated, are late, don't comply with specifications and standards due to failure in properly designing, specifying, following up, or installing any of the components, the facility won't work. This will mandate extensive rework, additional financial resources, and more time for completing and commissioning. Time to market, expected revenue and profits, and competitiveness will suffer by using resources inefficiently and ineffectively. For these reasons, the development, control, quality assurance and timely integration of all the deliverables of major capital projects is of paramount importance; this calls for careful implementation of all the steps of a sound PDP in all its details.

On the other hand, small projects or ones with low complexity or limited technological challenges typically require more modest resources in terms of project team size and skills, contractor's capabilities and financial resources. Some of these projects might even be executed in a similar or repetitive manner, or by applying just a limited number of project assurance protocols, considering the typical short duration of such projects. As a consequence, the number of deliverables to fully specify/design the project or its components is very limited. These small projects, because of their size or low complexity, are easier to visualize and understand.

PARAMETER/ATTRIBUTE	LARGE PROJECTS	SMALL PROJECTS
Objectives	Corporate	Organizational
Business case	Detailed	Basic or occasional
Stakeholders	Many	Few
Cost	High	Low
Schedule	Thousands of activities	Tens to hundreds of activities
Time to completion	Long	Short
Project assurance	Extensive and detailed	Few
Deliverables	High volume	Low volume
Funding	Typically required	Typically internal funding
Project team	Large organization	Plant-based
Project execution plan	Detailed, massive	A few pages, standardized
Approval and Followup	Corporate	Organizational
Procurement	International	Typically local
Contracting	Extensive, large contractors, multiple Interfaces	Single, smaller, local contractor
Complexity	High	Low
Technology	Frequently cutting-edge	Typically proven
Risk Assessment	Formal, extensive with mitigation plans	Less formal, basic
Communication plans	Extensive, regional exposure	Minimal — local, internal audience
Contingency plans	Extensive	Basic

TYPICAL DIFFERENCES BETWEEN LARGE AND SMALL PROJECTS

Table 1. Smaller projects don't pose the same issues as larger ones.

THE IMPACT ON APPROACH

The differences between large and small projects are extensive, many of them of significant importance and affecting all (or most) of the steps of typical PDPs. Table 1 compares large and small projects for some typical parameters/attributes associated with PDPs. It points up why you should take these major differences into account when defining or deciding the proper track for a particular project. All major projects should implement and follow, in detail, the instructions or provisions associated with each step of the PDP. However, for smaller projects, and depending on their nature and characteristics, we either skip some of the

steps — e.g., business case, contingency plans, communications plans, application of benchmarking and VIPs (as part of project assurance), etc. — or reduce or scale down the level of detail required by some of the steps (e.g., project execution plan, schedule level, risk assessment, etc.).

Let me reiterate: rigorously applying all PDPs steps and protocols to small projects will waste resources, extend project execution time, add costly test/procedures, likely enlarge the project team and lead to more expensive contracts. The magnitude of the project simply doesn't justify such extra effort, time and cost.

Clearly, determining the proper PDP track for a project is important to ensure an efficient use of valuable resources and optimize the project execution in terms of cost and time.

A VALUABLE TOOL

Most organizations are rebuilding their PDPs to respect their repositioned capital programs as well as to address the issue of less-experienced project teams. This has generated the need for a project characterization step and its supporting documentation/tool. Such a characterization step (through its tool function) directs the team through a series of questions whose answers can guide in adapting the PDP to one that best suits the project's needs. This characterization isn't based solely on project expenditure or cost but also takes into account new or existing technology, required completion date, resource availability, etc. The resulting evaluation directs the process to turn on and off various project planning and execution activities, which then leads to the appropriate level of work to drive the project to completion.

The tool provides a suggestion that can be overridden if the project team and the gate-keeping team agree that other activities should be implemented or avoided. The overall objective of the tool is to apply the truly value-added steps in the PDP and eliminate the non-value-added work. Effective implementation of this step has

resulted in minimizing excessive project planning paperwork, utilizing appropriate owner resources and, ultimately, achieving cost and schedule savings.

A characterization tool typically is tailored to the owner organization's PDP and project complexity parameters. In some industries, companies might consider capital projects of less than \$25 million small, others would define a small project as one costing under \$1 million. The definitions of other parameters outlined above also vary widely. Therefore, an initial activity in developing this PDP characterization step often is an alignment session around the owner's philosophy of requirements at each phase of project delivery for various project types. This then results in an activity to document these criteria and build the tool. These activities shouldn't take longer than 2-3 days to complete but add great value in clarifying the expectations of senior management and the project team at each of the phase gates.

Figure 2 illustrates a portion of a characterization tool. The tool tends to be specific for particular industries and even companies; the version shown just provides an example of the factors and associated questions used to determine the right track for a project when implementing the PDP steps.

This example, suitable for projects in the oil-and-gas downstream sector, considers three major factors:

1. Technical complexity — in terms of commercial challenges, key project-specific parameters and technology consideration or sensitivity, i.e., proven vs. cutting edge technology; licensed vs. open technology; capital cost vs. operating costs vs. lifecycle costs; safety issues associated with competing technologies; etc.;
2. Size, represented by cost/value; and
3. Special project drivers such as expected revenues, regulations or challenges associated with the execution and its constraints.

As indicated, the factors, questions and relative weight of each issue considered typically are industry- and, many times, company-specific. So, selection generally takes place in a facilitated workshop, bringing together the business strategic vision and the project management expert knowledge.

In the example shown, with the exception of the project value information (value at risk), the tool only requires yes/no answers. It internally applies the conversions, weights and grades agreed to in the workshop, resulting in a characterization of the project into one of three classes where Class 1 represents the upper level in terms of criticality and Class 3 the lower end. In this particular case, the classification of projects into three categories allows the definition of a project's "routes" or "tracks." The team

SAMPLE CHARACTERIZATION TOOL
Figure 2. Tool uses yes/no answers for most questions and pre-determined weights to place project into a particular class.

that risk unnecessary and auto-inflicted overruns in cost and time.

Before its application, the tool needs customizing for the particularities of the industry/company the project is in. This usually brings some other relevant perspectives worth exploring during the characterization process such as: PDP considerations and simplifications in case of projects of repetitive nature; complexities derived from very sensitive site locations (i.e., ecological issues); contractors' market conditions substantially affecting contracting strategies; few suppliers for key components or services; insufficient owner skills or resources to exert project oversight; etc. Simple projects can migrate quickly into a complex condition when combined with some of these issues.

Typical misconceptions about project complexity include:

- Working on the basis that all projects are equal and the same PDP process applies;
- Using size (i.e., dollars) as the only characterization factor;
- Disengaging or limiting senior business and operational participation during the characterization process, or avoiding proper periodic project oversight during the FEL by these functions;
- Underestimating the importance of developing a formal business case that includes sensitivity analysis as the basis for project characterization;
- Assuming that selection of a low-level project track means lack of rigor in developing and reviewing the project deliverables;
- Characterizing the project without previously defining and approving the business and project objectives; and
- Failing to match the project team's profile and skills to project characteristics and requirements/challenges.

Finally, it's important to keep in mind that the relevance and applicability of these issues and factors depend upon industry sector. Every industry has particular factors

that always deserve serious consideration or proper emphasis when characterizing a project. These factors include:

- Geopolitical factors and organizational/coordination challenges (i.e., large oil-and-gas upstream/downstream);
- Communities and regulations (i.e., pipeline, oil-and-gas midstream);
- Patent protection, regulations and validation requirements (i.e., pharmaceuticals);
- Financing options, efficiency, contracts' synchronization (i.e., power); and
- Quality/complexity of mineral deposits, availability of infrastructure, location (i.e., mining).

UPGRADE YOUR APPROACH

The characterization tool should become a mandatory addition to an owner's PDP. It enables differentiating between projects of varying nature and characteristics to optimize the use of organizational resources — eliminating non-value-added work and producing significant savings in cost and time. ●

IVAN CRESPO is vice president of Pathfinder LLC, Cherry Hill, N.J. Email him at ICrespo@pathfinderinc.com.

Successfully Sample Sticky Hydrocarbons

Proper technology and design techniques ensure safe, reliable sampling of viscous and hot process streams

By Seth Martin, Tech-SORce and Billy Terry, SOR Controls Group

In the refining and petrochemical industries, the term “heavy products” is used when describing streams such as heavy gas oils, tars, resins, asphalts or bitumen. Collecting samples of such media presents a unique set of challenges for petroleum processing facilities; often the materials sampled are hot, viscous and even corrosive, making them particularly hazardous for operators to collect and transport for analysis. Using a dedicated system to collect samples of heavy products is further complicated by the media’s sticky consistency and tendency to solidify and clog up the system’s piping.

Designing a heavy products sample station (Figure 1) that can resist plugging while still maintaining personnel safety is an important part of establishing the system as an



SAMPLING STATION

Figure 1. Sampling heavy gas oils, tar, resins, asphalts or bitumen is accomplished with a well-designed heavy product sampling station.

effective engineering control. In practice, it is more difficult than it seems on the surface. For anyone who has been tasked with designing and installing a sample system for residuum in a refinery or surfactants or resins in a chemical processing facility, the experience undoubtedly was similar. While every sampling application has its own set of challenges, some specific design techniques can be used to mitigate long-term issues associated with closed-loop grab sampling stations used for heavy products.

THE FAST LOOP IS FUNDAMENTAL

Regardless of the process media, one of the most commonly used and important features of liquid grab sampling is the incorporation of a fast loop in the design. Simply put, the fast loop is an interconnected section of piping where liquid travels from the process line to the sample station for collection and back to the process line. The fast loop's purpose is to deliver the process stream directly to the sample station so that the collection obtained is representative of the process at the exact time the grab sampling occurred.

The fast loop is a far better method for obtaining representative samples when compared with other techniques, such as running the process media to a drain or sewer to eliminate dead volume before a sample has been gathered. Fast-loop or speed-loop designs also are used when designing online analyzer applications for the chemical and petrochemical industry. Figures 2a and b show two common methods for incorporating a fast loop into an engineered sample point.

PULLING THE PLUG

Another benefit of the fast-loop design is the elimination of dead volume in the system's piping. Dead volume refers to the sections of piping or tubing that connect the process with the sample station, or within the sample station itself, where media can become trapped and unable to move with the flowing sample stream (Figure 3). For heavy products, which tend to resist flow, dead volume in a sample station leads directly to plugging. Plugging the fast loop or the sample station will require

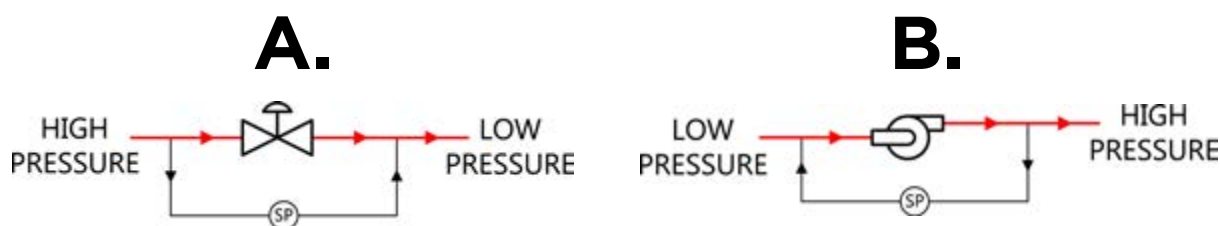

SAMPLE POINT FAST LOOPS

Figure 2a and 2b. Two common methods exist for incorporating a fast loop into an engineered sample point.

taking the unit out of service until it can be repaired.

Rather than incorporating a fast loop, some designs may forego the extra piping in favor of installing a ram/piston-style sample valve directly into a process line as an alternative means of reducing dead volume. All valves include some type of stem packing that has a finite lifespan and eventually will leak. If the production operation is continuous and you select a ram/piston type of valve without a fast loop, you could be forced to shut down the entire process line to repair the valve if it begins to leak.

TOO HOT TO HANDLE

One of the primary obstacles associated with sampling heavy products is

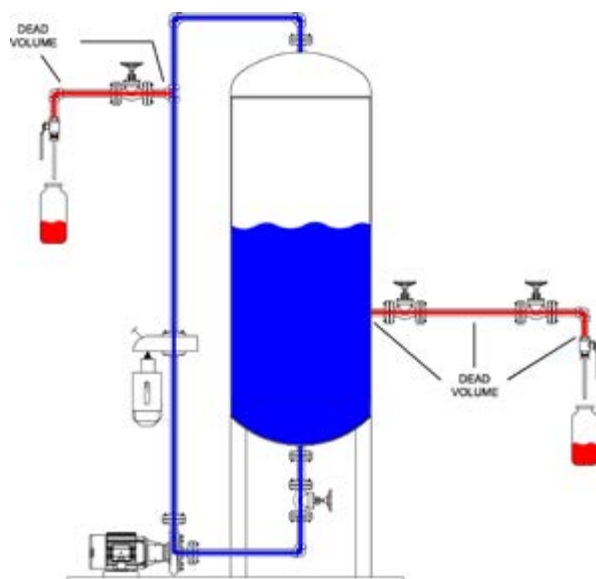

DEAD VOLUME

Figure 3. Dead volume in a sample station can lead to plugging.

A Clear Tip

Clearing the sample path after use can eliminate sample contamination and risk of plugging, but don't use a slop container. To clear the sample path with STEAM, use an adapter and hose assembly to direct the residual sample to a drain located in the bottom of the enclosure to keep the sample station clean and operational.

overcoming the temperature dependence of liquid viscosity. The chemical reactions and physical processes associated with heavy products often involve extremely high temperatures, so there may be a desire to cool the process stream before it reaches the sampling station. However, cooling a resin or a residuum low enough to retrieve the sample container by hand will cause the product's viscosity to increase, sometimes even solidifying, which could lead to the unintended consequence of plugging the entire grab sample station, rendering it unusable.

Instead of attempting to reduce the sample's temperature to a touchable level, consider a design that allows the sample valve to be operated from outside an enclosure, preventing operator exposure to splash or burn hazards. Rather than cooling the process before collection, allow the sample to cool inside the station's enclosure before retrieval and transportation to



SAMPLE PATH FLUSH CONFIGURATION

Figure 4. Use a twist lock flush adapter to direct steam and waste media in the sample pathway to the enclosure drain.

the lab. Letting the sample cool will require laboratory technicians to reheat the sample before analysis, but, in most cases, this does not present a problem and already is in practice.

ISOLATING THE STEAM PURGE AND SAMPLE LINE

Another important design often incorporated into heavy product sampling stations is the combination of steam heating and purging utilities used in conjunction with a flow-through style sample valve (Figure 4). Steam heating is an effective method for reducing the likelihood of plugging by imparting heat to the process stream, elevating it to temperatures that ensure the media will not be resistant to flow. Likewise, steam purging is used to clear the sample path of trapped process media when

resolving plugging issues and potential sample contamination.

In addition, the flow-through style of sample valve gives the added benefit of isolating the sample path from the sample flow line, making it possible to purge the sample path independent of the process flow while the sample valve is in the closed position. Designs that block or partially block the process flow path to steam-purge the sample valve often will exacerbate plugging issues, requiring the sample station's complete removal to clear the line.

It is easy to understand why separating the sample path through the valve from the process sample line is advantageous in heavy product applications. When localized plugging occurs, the steam purge clears the blockage from the sample path without disrupting the process flowing in the sample line, clearing trapped material and eliminating the potential for sample contamination.

A REPLACEABLE CARTRIDGE FOR REDUCING REPAIR TIME

One final design feature often integrated with heavy product sampling systems is a sample valve with a removable and replaceable cartridge system that includes the sample valve's seat and ball/stem assembly. Many of the sampling stations installed in heavy product applications are mounted into piping systems, with a traditional process valve and welded or flanged connections.

Performing maintenance requires removing the entire welded pipe spool from the process line, thus lengthening the overall time and effort needed to complete the repair.

Conversely, a sample valve with a removable/replaceable cartridge allows for separating the valve's critical components from the sample line without removing the valve body and pipe spool from the process line. In the event the sample valve encounters a plugging issue, the plugged cartridge can simply be removed from the sample valve body and replaced with a new one, whereas servicing a sample station mounted into a piping system involves multiple maintenance disciplines.

As shown in Figure 5, when it comes to the task of collecting heavy product samples or designing a system to do so, you must be prepared to consider and confront some unique challenges. However, with careful planning and a well-thought out sampling system design, incorporating some or all of these techniques, a sample of even the heaviest of products can be collected in

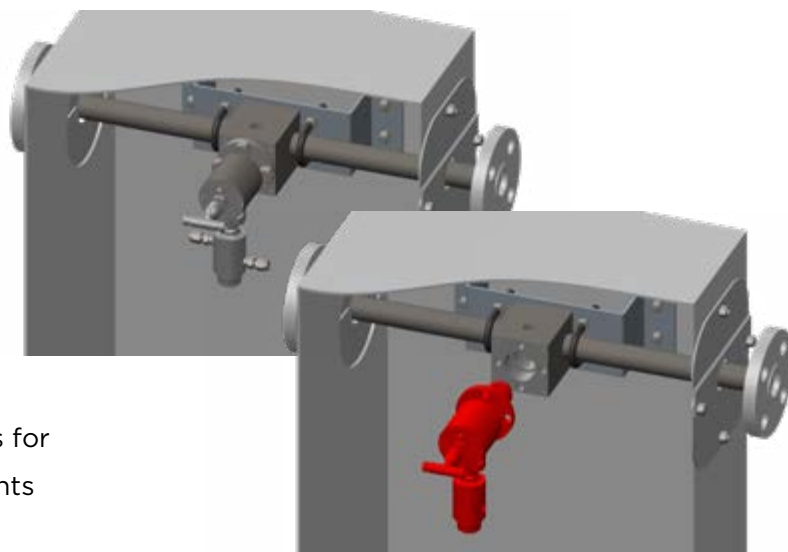

REMOVABLE CARTRIDGE SYSTEM

Figure 5. This removable cartridge system includes the sample valve's seat and ball/stem assembly.

a safe, reliable manner that is representative of your process. Although the risk of plugging always is present in these applications, you can increase the availability and reliability of this type of engineering control without increasing risk to operations while also reducing downtime when upsets occur. ●

SETH MARTIN is president of Tech-SORce. He can be reached at smartin@sensoreng.com. **BILLY TERRY** is a product manager at SCG Controls Group. He can be reached at bterry@sorinc.com.

Mitigate Explosions with Oxygen Measurement

Select the right oxygen analyzer for your process control requirements

By Narge Sparages, BHGE

Among plant management's concerns are ensuring employees get home safely at the end of their shifts and that its operations don't impact its neighbors adversely. In many plant operations, product is stored in tanks and other vessels. Hydrocarbon vapors may be found in the head space of these vessels or in reaction vessels, biomass storage vessels and grain storage. The presence of oxygen along with an ignition source can lead to an explosion with devastating results and product loss.

Purging the head space in a storage vessel with nitrogen minimizes the presence of volatile organic compounds (VOCs) and oxygen and thus reduces the possibility of an explosive mixture. Without a fuel source and oxygen, little opportunity exists for an ignition source to enable an explosion (Figure 1).

The blanket gas provides the added benefit of lessening corrosion of the storage vessel and associated equipment because it removes the moisture that can come in with the ambient air.



REQUIREMENTS FOR COMBUSTION
 Figure 1. Reduce the opportunity for an explosion by reducing or eliminating the presence of oxygen and fuel.

A nitrogen purge or blanket also can be found in reactors to control the amount of oxygen present to ensure product quality. Nitrogen is used as the blanket gas as it is inert, relatively inexpensive compared to other options such as carbon dioxide and readily available. The nitrogen's source is based on the storage vessel or reactor's size. It can come from an adjacent air separation plant or, if the purged volume is small, from cylinders or dewars.

Adding oxygen measurement to purge systems helps mitigate the presence of explosive mixtures, thus ensuring an effective purge. Oxygen measurement also can help reduce costs, allowing the control system to use only the amount of nitrogen necessary to prevent a hazardous mixture.

A short list of applications that would benefit from oxygen measurement include:

- Storage of hydrocarbon liquids such as benzene, hexane, toluene and styrene;
- Fire suppression of biomass fuels;
- Mixing vessels used to dissolve viscous adhesive gels in hexane;
- Oxidation reaction for Noryl resin suspended in toluene;
- Oxidation reaction between p-Xylene and acetic acid to make purified terephthalic acid (PTA);
- Industrial centrifuge, separation of makeup solids from hydrocarbon liquid; and
- Glove boxes used in all types of medical, biomedical and pharmaceutical processes.

THE INERTING PROCESS

During storage, transportation or manufacturing of chemical, biochemical or organic products, the presence of VOCs, oxygen and potential energy sources can lead to fires or explosions. These organic compounds may be needed, as they are part of the process. Eliminating ignition sources is difficult because it may not be practical to ensure no static electricity is stored in the system. As a result, removing the oxygen necessary to support combustion may be the only lever available to mitigate danger.

Inerting and blanketing are applied in closed vessels that have a head space above a stored product or in a reaction vessel. Nitrogen, typically under slight positive pressure, is added to remove the oxygen that may be present as part of the process or that finds its way into the process from the ambient air. The nitrogen may be free-flowing, especially in systems with little ability to maintain a positive pressure.

In cases in which positive pressure can be maintained, pressure control may limit the amount of nitrogen expended as a blanket. In both examples, there is no assurance that the purged/blanketed space cannot support a fire or explosion. Ensuring a safe environment in the head space by oversupplying nitrogen can be expensive.

Adding an oxygen measurement can indicate when enough oxygen is available to

cause a potential hazard (Figure 2). It would feed back to the nitrogen supply system to add nitrogen or, in the case of a gross leak of oxygen into the system, provide an alarm state indication for an operator to take action.

The oxygen measurement also can help control the amount of nitrogen used to blanket the process. In most systems, the oxygen doesn't have to be removed completely. Knowing the oxygen concentration allows the operator to control the nitrogen supply, thus providing a safe condition without waste. Some processes may need oxygen controlled within a desired range. An oxygen measurement can ensure that the oxygen concentration stays within those limits.

OXYGEN MEASUREMENT TECHNOLOGY

Several oxygen measurement technologies are available for process control. Choosing the most suitable oxygen analyzer for a specific application requires understanding the various technologies, their relative purchase prices, implementation costs and maintenance requirements. The technologies featured here are among the most commonly used for purge or blanket applications.

Paramagnetic oxygen analyzers. Oxygen is paramagnetic, meaning that it is drawn to a magnetic field. Paramagnetic analyzers take advantage of this property.

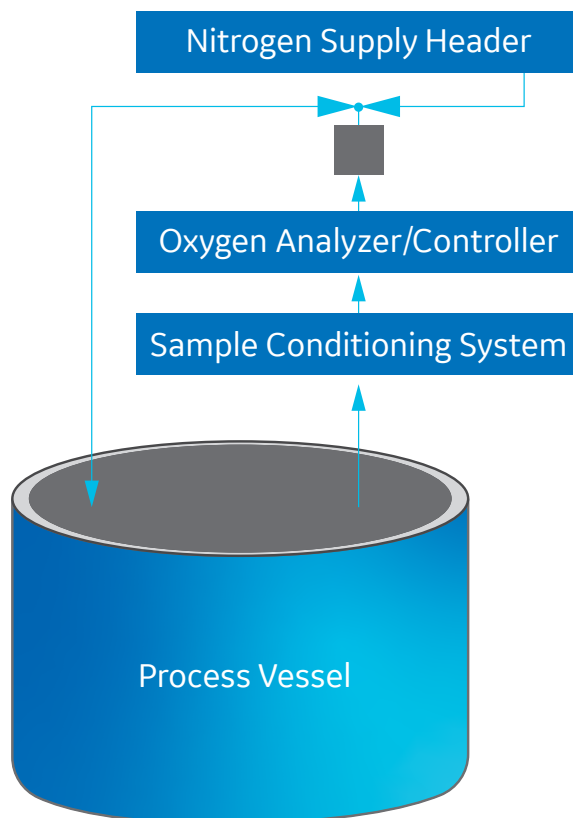

SCHEMATIC FOR TANK INERTING WITH O₂ ANALYZER

Figure 2. Adding an oxygen measurement will indicate potentially dangerous conditions.

In a typical paramagnetic oxygen analyzer sensor, two glass spheres are mounted within a magnetic field on a rotating suspension that looks like a dumbbell (Figure 3). A reflective mirror is located at the center of this assembly. Light shines on the mirror and is reflected onto photocells. As oxygen is attracted into the magnetic field, it causes the glass spheres to rotate. The photocells detect light from the mirror. The analyzer's circuit generates a signal to a feedback system, which passes a current to keep the spheres in their neutral

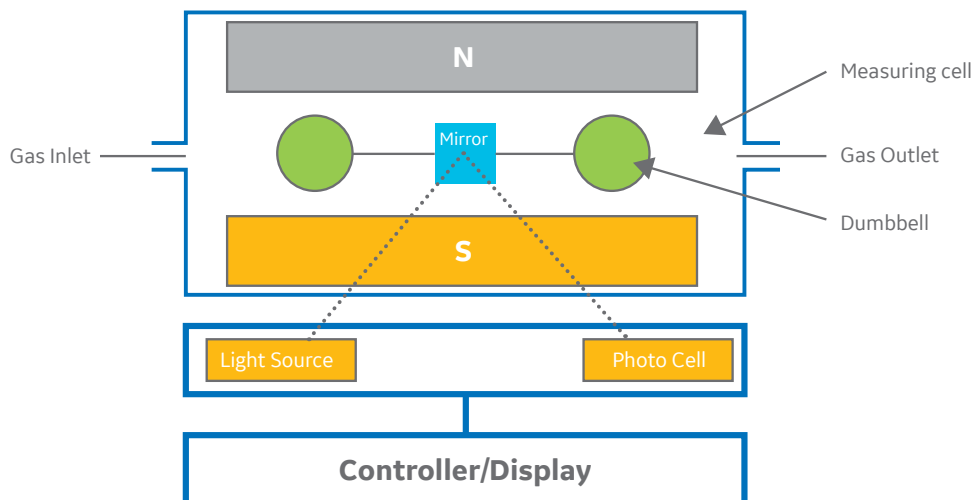

PARAMAGNETIC SENSOR SCHEMATIC

Figure 3. This long-lasting sensor generally is used to take percent oxygen measurements.

positions. This current is directly proportional to the oxygen concentration.

An advantage of this technology in this application is that interferences from other paramagnetic gases typically are not present. The sensors aren't consumed in making the oxygen measurement. With proper care, the sensor will last for many years. Liquid carryover can damage the sensor, requiring sensor replacement. This sensor typically is used for percent oxygen measurements.

Thermoparamagnetic oxygen analyzers.

Thermoparamagnetic technology also makes use of oxygen's paramagnetic properties. It does so without the need for moving parts.

The oxygen molecules are drawn into a magnetic field within and at the center of a measurement cell. This causes a partial

pressure difference within the cell. Matched thermistors at an elevated temperature provide a path for the oxygen molecules to leave the magnetic field. The heat from one thermistor in a pair is transferred to the second thermistor in the flow path. The thermistors are in a Wheatstone bridge circuit. The amount of heat transferred from the cooled thermistor to the heated thermistor and the resultant current required to balance the circuit are directly proportional to the oxygen content present (Figure 4).

With no moving or consumable parts, this technology is less susceptible to upset conditions with liquid carryover. It also is immune to the typical background gas composition variations found in these applications, as the sensor can compensate for these variations by monitoring for the total heat loss of the thermistors within the Wheatstone bridge.

The measurement system can be configured to autocalibrate the sensor using the purge nitrogen as a zero gas. This sensor typically is used for percent oxygen measurements.

The combination of no moving parts, highly stable calibration, autocompensation for background gas changes and the ability to mount it in a hazardous area with an autocalibration sample system and electronics makes this technology most applicable to inerting and blanketing gases in which condensing hydrocarbon vapors exist.

Galvanic fuels cell analyzers. With this sensor type, oxygen consumes lead (Pb) to produce lead oxide.

The cathode and anode are immersed in solution. The electrons released at the anode's surface flow to the cathode surface via an external circuit (Figure 5). This current is proportional to the amount of oxygen. The current is measured and used to determine the oxygen concentration in the gas mixture.

The reactions at the cathode and anode, along with the overall reaction, are shown here:

- Cathode: $O_2 + 2H_2O + 4e^- \rightarrow 4OH^-$
- Anode: $2Pb \rightarrow 2Pb^{+2} + 4e^-$
- Overall: $2Pb + O_2 \rightarrow 2PbO$

Diffusion membranes ensure that the current output is proportional to the oxygen concentration.

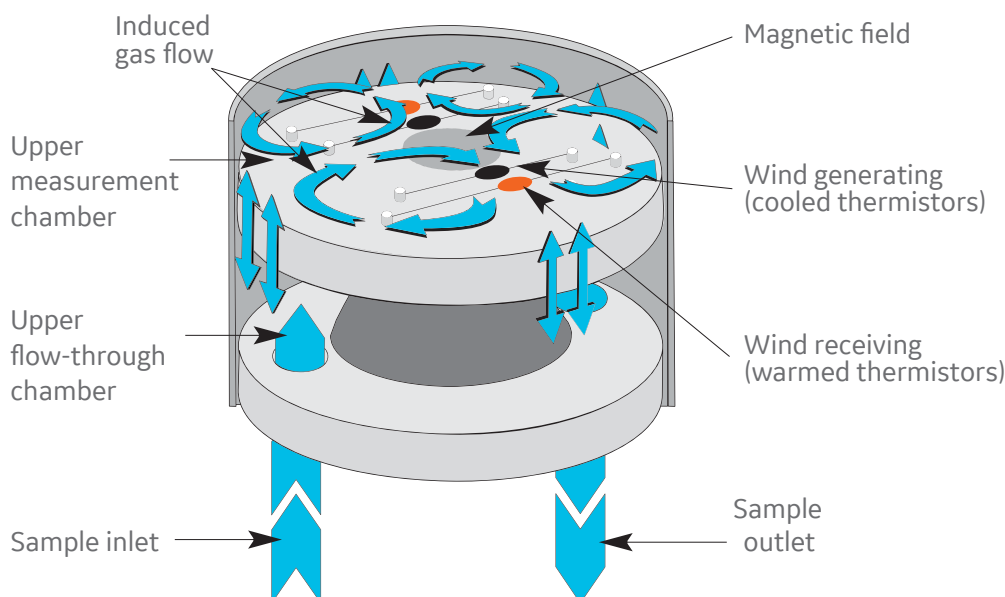

THERMOPARAMAGNETIC SENSOR SCHEMATIC

Figure 4. This sensor also is used for percent oxygen measurements but also can be mounted in a hazardous area.

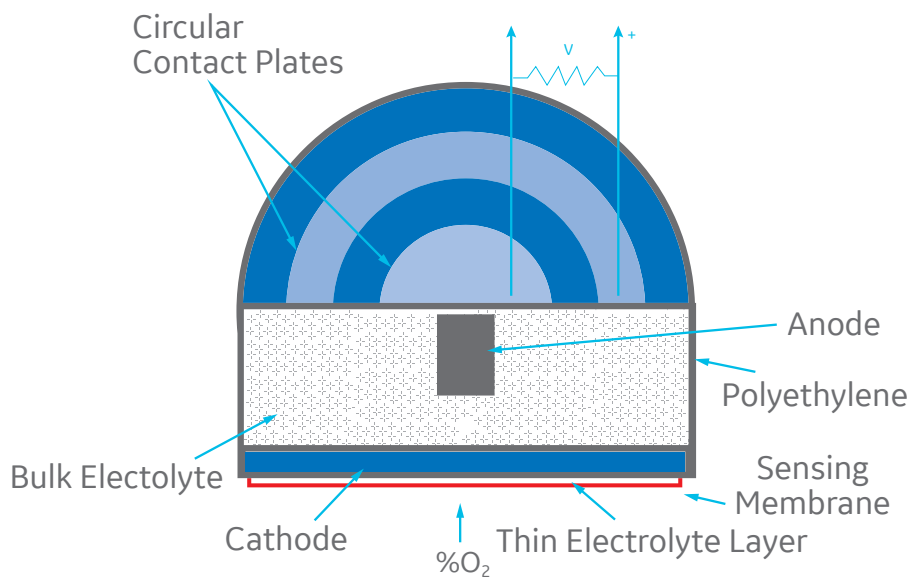

GALVANIC FUEL CELL SENSOR TECHNOLOGY

Figure 5. This sensor is used for percent ppm oxygen measurements and is well-suited for glove box applications as it is background gas-insensitive.

This technology provides the benefit a lower-cost solution. Because the sensor is consumed in making the measurement, spare sensors should be available. Typical lifetime for the sensor is a couple of years, unless fouled by liquid carryover, when a replacement will be necessary. The technology is background gas-insensitive.

This technology is applicable for both percent-level and ppm-level oxygen measurements. The ppm-level sensors are useful for inert atmospheres found in glove box applications.

Nondepleting electrochemical sensors.

This sensor type provides galvanic fuel cell flexibility with a less intensive maintenance schedule.

When oxygen is present in the sample, a current is produced in the measurement circuit that is proportional to the oxygen concentration. Unlike the galvanic cell, the measurement reaction is driven by an applied voltage across the measurement electrodes supplied from the instrument electronics. The secondary electrodes assist with acid gases and with the measurement's speed of response (Figure 6).

When ppm- or percent-level measurements are required with high level accuracy and when possibility of liquid carryover is very low, this technology offers stable and fast-responding oxygen measurements.

Zirconium oxide analyzers. This technology is not thought of often for this application

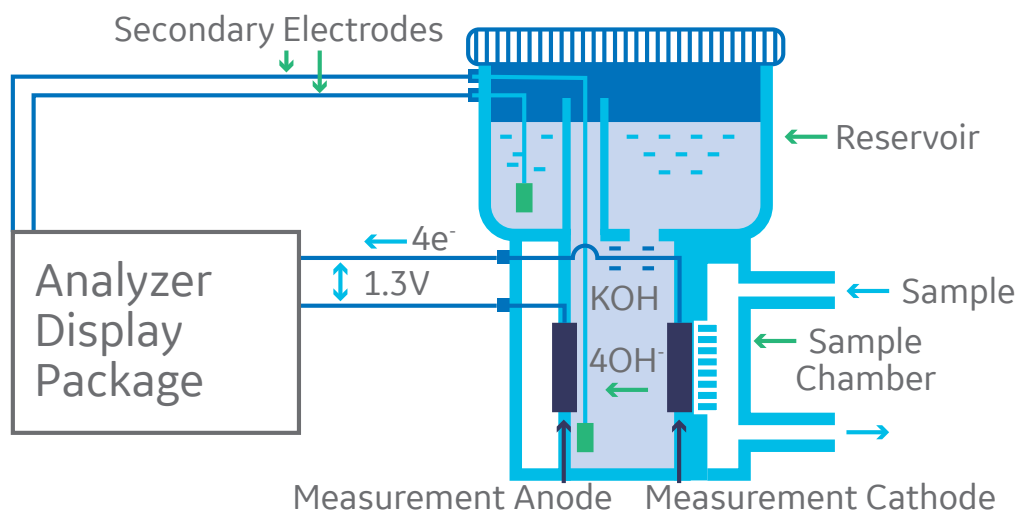

NONDEPLETING ELECTROCHEMICAL SENSOR

Figure 6. Under specific conditions, this sensor offers fast-responding oxygen measurements.

space, but when the background gas is fairly inert and speed is a prerequisite, zirconium oxide sensors offer a simple answer.

The zirconium oxide sensor typically is in the shape of a test tube (Figure 7). One side is exposed to ambient air as a reference gas and as a source of oxygen molecules. The other side is exposed to the sample gas. The zirconium oxide is doped with yttrium oxide, providing a means for oxygen to migrate through the sensor lattice. The sensor is coated with platinum and operates at an elevated temperature.

The lower the oxygen concentration in the sample gas, the more oxygen molecules migrate through the sensor, causing a change in the electrical voltage across the sensor. The mV reading is

measured, and the Nernst Equation (Figure 8) governs the oxygen concentration.

This sensor type's advantages are that it is the fastest-responding of the traditional oxygen measurement technologies and can measure oxygen from percent levels to the sub-ppm region. The disadvantage in many purging or blanketing applications is that it will combust any hydrocarbons with stoichiometric amounts of available oxygen, thus reporting a false low reading. This relegates this technology to applications in which the hydrocarbon levels are orders of magnitude below the oxygen concentration.

This sensor is ideal for glove box applications and for measuring oxygen in the nitrogen purge gas before injection (where this might be of interest or concern).

IMPLEMENTING THE MEASUREMENT

A properly designed sample system provides the sensor with the best chance for success. The design should ensure a continuous flow of the sample gas reaches the sensor and that the sample system doesn't change the sample's composition.

For glove box applications in which the nitrogen purge may pick up only small particulates, a simple filter will suffice, if needed at all.

On the opposite end of the spectrum, when purging nitrogen over a hydrocarbon liquid, either in a reactor or in a storage vessel, the extracted sample may carry hydrocarbons that will condense. Because liquid hydrocarbons will interfere with the measurement and may damage the sensor, the sample system design should account for

$$E_{12} = \frac{RT}{nF} \cdot \ln \left[\frac{P_1}{P_2} \right] \quad \text{where,}$$

F = the Faraday = 96,484.56 coulombs

T = absolute temperature = °K
(°K = °C + 273.15°)

R = gas constant =
8.31441 volt-coulomb/mole-°K

n = # electrons transferred
per molecule = 4/mole

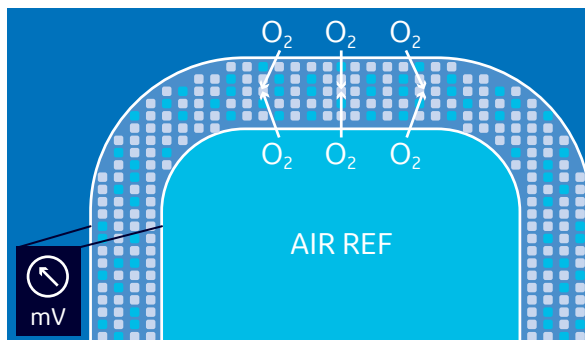

ZIRCONIUM OXIDE SENSOR SCHEMATIC

Figure 7. While this sensor gives quick readings, it must be used in applications containing hydrocarbon levels that are greatly below the oxygen concentration.

the removal of these liquids before passing the sensor.

Figure 9 shows a sample system that uses the purge nitrogen as the motive force to pull the sample out of the storage vessel by means of an eductor or aspirator. The gas cools as it enters the sample system, and any condensed liquids drop into the

ln = natural logarithm = 2.303 log₁₀

P₁ = O₂ partial pressure on
reference gas side = 0.2093

P₂ = O₂ partial pressure
on sample gas side

E₁₂ = voltage on reference with
respect to the sample face

NERNST EQUATION

Figure 8. Zirconium oxide sensors use this equation to determine the oxygen concentration.



SAMPLE SYSTEM FOR TANK BLANKETING

Figure 9. This system uses purge nitrogen to pull the sample out of the storage vessel. The sensor used has a zero-gas requirement.

liquid dump. The sample passes through a secondary filter with a bypass drain before passing through a thermoparamagnetic oxygen sensor. The drains from the liquid dump and bypass filter and the outlet from the sensor are carried back to the storage vessel.

This specific sensor has only a zero-gas requirement. Because the nitrogen is a valid zero-gas, the sample system includes solenoid valves powered and controlled by an analyzer (not shown here). On a timed basis, the analyzer switches the system to calibration mode, passes the purge nitrogen through the transmitter and stores the corrected calibration at the analyzer.

MAKING A SELECTION

Safety, asset protection and blanket integrity are vital to plant and process operations. The range of oxygen measurement technologies and the selection of the correct solution to meet individual challenges require research and comparison.

The technology needs to be accurate, reliable, easy to use and maintain. It should have the proper balance between up-front purchase price and the cost to maintain, and these costs should be aligned with the plant's expectations.

NARGE SPARAGES, is senior product and services manager for Panametrics, a part of BHGE. He can be reached at Narge.Sparages@bhge.com

Successfully Select an Industrial Fan

Gathering site and fan history is crucial when choosing the right unit for the application

By Steven F. Back, New York Blower

When selecting a custom, engineered-to-order (ETO) heavy industrial fan (Figure 1), you need to make your fan vendor aware of certain basic requirements. These include the fan specifications, regional codes, drawings and photos of the process, details about the location, information about the installation, and last but not least, details about the process.

However, some of the most important information almost always is lost in the request for quotation (RFQ) process. This is the invaluable history of the fans operating in a similar ventilation or process scenario. A fan's durability, reliability, useful life and operating cost will change with the many different ventilation and process applications.

HISTORY IS KEY

Heavy industrial fans have been around since the first industrial revolution in the 1800s. History of what has and hasn't worked is abundant and obtainable. However, most of the difficulty in collecting history lies in



INDUSTRIAL FAN

Figure 1. An industrial fan's durability, reliability, useful life and operating cost will vary with the many different ventilation and process applications.

where to find it. The following situations can make it difficult to collect equipment history:

- Knowledge often leaves with personnel during layoffs.
- The fan is for a new process or ventilation scenario with no history available.
- Engineering, maintenance and purchasing are not communicating effectively.
- An engineering firm separate from the plant site is working on the specification.
- Plant management believes that history has no value because it is requesting the “very best” fan at the least initial cost and quickest delivery.

Collecting and passing along a written document of a fan’s performance history will work, but it isn’t the best option. Instead, a pre-quote or predesign meeting in which all parties can listen to each other, ask questions and start a knowledge-gathering session about the history of fans in similar processes and ventilation scenarios will put you on the right path to choosing the correct fan for your application.

It’s important to communicate to your fan vendor what has and hasn’t worked from the perspective of the people erecting and maintaining the fans. This is the case for new equipment and when rebuilding, upgrading or retrofitting existing fans. This information should be included when writing the fan specification. However, often it gets diluted or forgotten all together by the time the RFQ gets to the fan supplier.

Personnel needed in the meeting should include the experts who install, maintain and oversee equipment maintenance. These suggestions can help address some of the challenges when collecting equipment history and ensure a successful planning meeting:

- If personnel turnover has left little experience, consider bringing in personnel from a similar operation in your company.
- If the fan is for a new process or ventilation scenario, ask the fan supplier for its recommendations of similar processes and bring in experienced fan technical service personnel to the meeting.
- If there is little or no communication between engineering, maintenance and purchasing, then talk with the site’s maintenance manager.
- If an engineering or procurement firm is creating the fan RFQ, request they attend the meeting.
- If you, the customer, want the “very best” fan at the “very best” cost and delivery, then, once again, the fan vendor needs permission to talk with the maintenance manager to get some history and insight.

When you have key personnel at the table, amass details large and small about the equipment, site and other variables such as vibration and temperature. Be sure to address the any previous performance issues and ask these questions:

Past fan failures. What fan failures (Figure 2) have you had in the past and how did



WHEEL FAILURE

Figure 2. Addressing past performance issues such as this wheel failure can help you properly select a new fan and avoid such issues from repeating.

you fix them? What are the most frequent fan problems that you have experienced?

Bearings and lubrication type. What has been the best performing bearing and lubrication type on similar fans with similar operating conditions and arrangement? Do you have bearing leaks and, if so, where? Do you have any trouble changing the bearing? If so, what? Have there been any bearing problems (Figure 3) due to the operating environment?

Couplings. What has been the best performing coupling on similar fans with similar operating conditions and arrangement? Is this coupling being used on variable-speed or constant-speed fan? What type of lubrication does it use? Are you having any problems with this coupling?

Shaft and bearing seals. What type of bearing and shaft seals are being used on your

fans? What is the best performing seal on your bearings? Do you have any trouble changing the seals? If so, what? Have you experienced any sealing problems because of the operating environment?

System effects. Does the fan experience any significant vibration from the airflow? Are any of the ducts, expansion joints, dampers, silencers, etc., attached to the fan experiencing vibration or fatigue cracks? Is there any whistle or rumbling sound emitted from the connection ducts or fan?

Motor. Does your plant have a preference for any manufacturer? What enclosure and cooling do you prefer for the motor? Does the motor or fan need a brake for maintenance?

Maintenance. Has the operations group considered what is needed to remove the maintenance sections on the fan housing



BEARING LUBRICATION

Figure 3. Lack of proper bearing lubrication compromised this fan's performance.

and lift out the rotor? Can the motor be lifted off the foundation and replaced?

Wear. Do the fan rotor and housing experience any significant wear (Figure 4) from the airstream? If so, what type of wear protection works best for this fan? How often do you repair or replace the wear protection? Do you have any samples of the dust or a chemical and particle size analysis of the dust? Do you know how much dust goes through the fan?

Corrosion. Do the fan rotor and housing experience any significant corrosion from the airstream? If so, what type of corrosion protection and construction materials work best for a fan in this process? How often do you repair or replace the parts of the fan exposed to the airstream? Do you have a chemical analysis of the airstream?



FAN WEAR

Figure 4. Depending on the application, ask your van vendor for suggestions for proper protection from wear.



FAN DELIVERY AND INSTALLATION
Figure 5. Provide information to your fan supplier about dock facilities so they can deliver and install the fan without issue.

Instrumentation. Does your operation a type preference for temperature, speed, vibration and pressure sensors? Are your sensors hard-wired or battery-operated? If battery-operated, are they communicating via Bluetooth, Wi-Fi or cellular?

Shipping and receiving. What type of unloading facilities do you have for the equipment being received (Figure 5)? Crane capacity and hook height? Will the equipment be stored inside or outside? Will power be available for the motor heaters? Will the rotating equipment be accessible to be spun to keep the bearings lubricated according to the instruction manual?

Foundations. Have you experienced any cracking in the foundations? Do vibration readings on the fans change during freeze/thaw cycles, dry/wet cycles? Do you feel any vibration from the foundation while the fan is running?

Environment at the site. Is the fan inside or outside a building? What are the site elevation and weather conditions? What are the noise abatement requirements for the fan? Will the fan be connected to a stack, which could facilitate transmission of a pure tune to the surrounding neighborhood? Will the fan see extensive heat, cold, ice, snow, rain, dust or humidity?

SUMMARY

As the number of employees continues to decrease as a result of economic

pressures and automation, the fan supplier should spend more time helping with customer research and documenting equipment history.

Selecting the appropriate industrial fan involves gathering considerable information. A knowledgeable and experienced partner can guide you in the selection process, resulting in the right fan for the application at hand.

STEVEN F. BACK is director, Heavy Industrial Fans at New York Blower. He can be reached at sback@NYB.com.

CHEMICAL PROCESSING

LEADERSHIP | EXPERTISE | INNOVATION

ADDITIONAL RESOURCES

EHANDBOOKS

Check out our vast library of past eHandbooks that offer a wealth of information on a single topic, aimed at providing best practices, key trends, developments and successful applications to help make your facilities as efficient, safe, environmentally friendly and economically competitive as possible.

UPCOMING AND ON DEMAND WEBINARS

Tap into expert knowledge. *Chemical Processing* editors and industry experts delve into hot topics challenging the chemical processing industry today while providing insights and practical guidance. Each of these free webinars feature a live Q&A session and lasts 60 minutes.

WHITE PAPERS

Check out our library of white papers covering myriad topics and offering valuable insight into products and solutions important to chemical processing professionals. From automation to fluid handling, separations technologies and utilities, this white paper library has it all.

MINUTE CLINIC

Chemical Processing's Minute Clinic podcast series is designed to tackle one critical issue at a time — giving you hard-hitting information in just minutes.

ASK THE EXPERTS

Have a question on a technical issue that needs to be addressed? Visit our Ask the Experts forum. Covering topics from combustion to steam systems, our roster of leading subject matter experts, as well as other forum members, can help you tackle plant issues.

JOIN US ON
SOCIAL MEDIA!

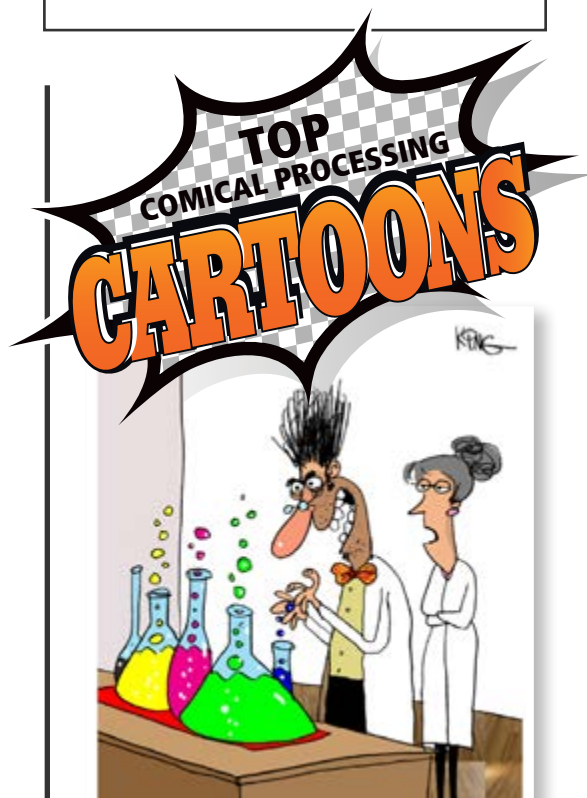

Visit the lighter side, featuring drawings by award-winning cartoonist Jerry King. Click on an image and you will arrive at a page with the winning caption and all submissions for that particular cartoon.